



USER MANUAL

FISCAL PRINTER UPOS-FP20 ONLINE

The company Exorigo-Upos has put all efforts so that the information included in this document be correct and reliable. However, the company Exorigo-Upos does not bear any liability for consequences arisen out of use of the information, as well as it reserves the right to make changes without prior informing the interested parties. This publication replaces all previous publications regarding the above subject.



It is not forbidden to throw away any waste electrical and electronic equipment with other non-sortable municipal waste!

The above designation of the product or packaging informs that waste electrical and electronic equipment may not be thrown away with other waste coming from a household and there is an obligation to hand it over to any organization or other entity which deals with collecting and processing of waste electrical and electronic equipment (the Polish journal of laws: Dz. U. 2015 poz. 1688).



It is not forbidden to throw away waste batteries and accumulators with other non-sortable municipal waste!

Waste batteries and accumulators should not be thrown away with other waste to the same container. There is an obligation to hand the waste batteries and accumulators over to any organization or other entity which deals with collecting and processing of selective waste (the Polish journal of laws: Dz. U. 2009 nr 79 poz. 666).



The equipment has been designated with the CE mark, confirming its compliance with the applicable requirements of the European Union directives within the electromagnetic compatibility 2014/30/EU, voltage range 2014/35/UE oraz RoHS3 directive 2011/65/EU + 2015/863 (UE).

This instruction manual does not constitute a commercial offer within the meaning of the Civil Code.

At the equipment manufacturer's website there have been made available all necessary certificates, instructions and service software applied for review and verification of the printer's data on a computer.

TABLE OF CONTENT

1 GENERAL INFORMATION4

1.1. TERMS OF USE 4

1.2. SEALING THE PRINTER 5

1.3. EXPLANATION OF TERMS 6

1.4. BASIC TERMS OF OPERATION OF THE PRINTER..... 7

1.5. DAILY FISCAL REPORT AND PERIODICAL FISCAL REPORT 7

1.6. REACHING THE CAPACITY OF THE FISCAL MEMORY 9

1.7. TERMS OF PRINTING VAT INVOICES..... 9

2 CONSTRUCTION OF THE FISCAL PRINTER10

2.1. BASIC ELEMENTS10

2.2. SIZING10

2.3. INTERFACE CONNECTORS12

2.4. CONTROL PANEL13

3 UNPACKING AND PREPARING FOR WORK15

3.1. COMPOSITION OF THE PACKAGING.....15

3.2. CONNECTING THE PRINTER WITH THE COMPUTER16

3.3. DRIVERS, SOFTWARE, INSTRUCTIONS, CERTIFICATES.....16

3.4. INSTALATION REQUIREMENTS16

3.5. SELECTION OF THE WORKPLACE OF THE FISCAL PRINTER.....16

3.6. BASIC PRINCIPLES OF THE PRINTER’S OPERATION17

4 OPERATION OF THE FISCAL PRINTER.....18

4.1. STARTING THE PRINTER.....18

4.2. OPERATION ON THE BATTERY18

4.3. SWITCHING OFF THE PRINTER19

4.4. CONNECTING THE PRINTER WITH THE COMPUTER19

4.5. INSERTING THE PAPER ROLL.....19

4.6. SERVICE ACTIONS.....20

4.7. CUSTOMER DISPLAY22

4.8. UPDATE FIRMWARE23

5 AUTONOMOUS MENU23

5.1. MENU OPERATION WITH USE OF PRINTER’S KEYS23

5.2. MENU STRUCTURE24

5.3. DAILY REPORT26

5.4. PERIODICAL REPORT27

6 TECHNICAL SPECIFICATIONS27

6.1. SPECIFICATIONS OF THE APPLIED PAPER27

6.2. PRINTER’S PARAMETERS28

7 DESCRIPTION OF EMERGENCY SITUATIONS.....29

8 ADDITIONAL SOFTWARE31

1 GENERAL INFORMATION

The fiscal printer UPOS-FP20 ONLINE of the company Exorigo-Upos is the tax payer's equipment for recording turnover from sales of goods and provision of services, as well as relevant tax amounts in real-time. So that the fiscal printer can fulfill its function, it is required to install a software for operation of sales on a computer and to have a stable internet connection. The fiscal printer UPOS-FP20 ONLINE allows also to print VAT invoices and commercial non-fiscal documents. It is possible to download a dedicated software archiving the electronic copy of documents, emitted by the printer.

1.1. TERMS OF USE

The user of the fiscal printer, as a tax payer, should observe a range of rules specified in the act of 11 March 2004 on the goods and services tax (the Polish journal of laws: Dz. U. 2004 nr 54 poz. 535 as amended), article: 111, the Regulation of the Minister of Entrepreneurship and Technology (Dz. U. 2018 poz. 1206) specifies the criteria and technical conditions which the cash registers should correspond with.

The applicable law lays down i.a. the following terms:

1. Unpacking and installation of the fiscal printer is held by an authorized service employee. The employee is obliged to prove his identity with the service provider's ID card, including the following data:
 - the service provider's photograph,
 - identification number,
 - service provider's signature,
 - service provider's first name and last name,
 - type of cash register,
 - address of the party conducting main service or service of cash registers,
 - date of issue of the ID card,
 - signature of the person authorized in the entity conducting main service.
 His last name should be entered into the 'Service log of the fiscal cash register'. His particulars will be entered into the communication scheme of the printer with the servers of the Central Cash Registers' Repository.
2. The tax payer is obliged to submit the necessity of a service intervention at the service provider who is entered into the list of persons authorized to perform service in 'The fiscal cash register service book' and is reported to the competent tax office.
3. The obligatory inspection of the cash register is made no less frequently than every 2 years. Failure to conduct the obligatory inspection is subject to relevant sanctions specified in the fiscal law regulations.
4. To 'The fiscal cash register service book' there are entered also particulars of the service provider authorized to substitute performance of service of a particular printer.
5. The user of the fiscal printer is obliged to keep 'The fiscal cash register service book' carefully in the place of its use and to protect it against access of unauthorized persons. It should be always at inspection authorities' disposal, above all at disposal of the tax office's representatives and service provider. The manner of its storage is subject to the regulations set out in the separate regulations.
6. All entries into 'The fiscal cash register service book' should be readable and entries on the service actions must be signed with the service provider's legible signature.
7. In the event of loss (misplacement, theft, etc.) of 'The fiscal cash register service book', one should immediately inform on it (personally or in writing) the competent service provider and competent tax office for issue of a duplicate. On 'The fiscal cash register service book' issued in such case, on its title page, the inscription 'A duplicate' should be placed. The printer must be subject to the service inspection.
8. In the event of failure of the fiscal printer, one should immediately call the authorized service provider, whose last name is entered into the service log. The service provider

is obliged to start the service actions within 48 hours from the moment of the submission. When the printer is not functional, as appropriate, one should conduct the sales with use of a spare printer, as substitution. The service log should be always prepared for each service intervention.

9. Each transaction must be ended with the receipt printed with the fiscal logo.
10. The user's obligation is due care of the proper quality of print. If the quality of print is improper, it is important to call the service provider.
11. The fiscal module placed in the fiscal printer, as the whole fiscal printer, has seals, tampering of which constitutes an offence.
12. The cash register must have two displays, one of which should be visible for the client. Switching off such equipment will result in suspension of the cash register system. In fiscal printers, the computer's monitor may play the role of the operator's display.
13. The user is obliged to provide with the internet connection of the printer with the CRK (Central Cash Registers' Repository) servers. All details should be consulted with the representative of the tax office competent for the tax payer. Information on the registered transactions, service events and inspections are provided in accordance with the schedule set by the Chief of KAS (the National Tax Administration). The Chief of KAS is the administrator of personal data transmitted by the fiscal printer.

Transfer of data with use of the communication protocol is secured in terms of confidentiality and integrity of data in compliance with the PN-ISO/IES 9594-8:2006 norm. All cryptographic actions ensure confidentiality and are performed in accordance with the ISO/IEC 11889-1:2015 norm in the TPM 2.0 standard.

NOTE!

The fiscal printer is an equipment under special supervision of tax offices; therefore, it requires special treatment and protection against destruction and theft.

1.2. SEALING THE PRINTER

Access to the interior of the fiscal printer UPOS-FP20 ONLINE is locked by a seal of modeling clay covering one of the screw fixing the base. The seal is the service seal and it has the engraved ID number of service provider's, issued by a national manufacturer or a party dealing with intra-community acquisition or import of cash registers.

NOTE!

Destroying seals by an unauthorized person is subject to consequences and penalties provided for in the Penal-Tax Act.

Only authorized service provider who is registered in the Tax Office, holds the right to tamper with the printer secured with the service provider's seal. The authorization is confirmed by the service ID card. At performing guarantee service, intact condition of the service seal is required. Each unsealing and sealing the fiscal printer must be recorded in the cash register book. The conditions of organizing and providing with service of cash registers have been included in the relevant Regulation of the Minister of Finance (the Polish journal of laws: Dz. U. 2019 poz. 816) regarding cash registers.

1.3. EXPLANATION OF TERMS

- **Non-fiscal mode of operation** – The printer is in this operation mode from the assembly by the manufacturer until conducting fiscalization by the authorized service provider. Working in this mode, the printer prints on the printouts the header without the line including the user's Tax Id. No. (NIP). Connection with CRK must be configured but no data is transferred.

Documents in the non-fiscal mode are marked with the inscription: 'NON-FISCAL', instead of the printout of the fiscal logo. The most important rule in this mode operation of the fiscal printer is no daily records to the fiscal memory. There is no permanent registration of sales to the fiscal memory and protected memory. Such condition lasts until the moment of conducting fiscalization. In relation to the above, one may not print reports which use the previously made reports to the fiscal memory, e.g. the periodical report.

- **Fiscalization** – It is a process when the printer connects through the internet connection with CRK with use of communication protocol of the specified by the Chief of KAS. The authorized service provider establishes a connection, completes the required scheme of information and sends the requirement to create the records of a particular cash register in the Information Technology system. CRK assigns the printer a record number. Since then, on the fiscal documents the fiscal logo will be printed and in the header the user's Tax Id. No. (NIP) will appear.

NOTE!
After fiscalization, it is impossible to return to the non-fiscal mode of operation.

- **Fiscal mode of operation** – The most important rule in this mode of operation of the fiscal printer is saving to the fiscal memory the information on sales and tax values from the period containing duration of fiscal day. It is a permanent record allowing to read the information later on. All receipts issued in the printer and not cancelled prior to their closing, affect the values saved to the fiscal memory in the form of a daily report. Data transmission to CRK is in accordance with the schedule set by the Chief of KAS or at the user's request.

NOTE!
If the fiscal printer has already been fiscalized and the user has noticed irregularities in its functioning, then the service should be immediately noticed on it and make proper entry into the equipment's service log.

- **Fiscal logo** – It is printed on the fiscal documents after conducting the printer's fiscalization. It appears at the end of the documents. It consists of the graphic sign *PL* and the unique number of the fiscal printer (it is always three letters and ten digits).
- **Fiscal day** – The period in the fiscal printer's operation with the beginning on the opening of the fiscal day (the first opening of the receipt) and ending in the course of preparing the daily report marked with the following, increasing number. In that period, the printer counts with each receipt the values of sales and amounts of taxes in particular rates and it sums up the data on the daily report. The printer does not close the fiscal day if a fiscal receipt is open. Closing or cancelling the receipt will allow to close the day.

1.4. BASIC TERMS OF OPERATION OF THE PRINTER

The manufacturer enters into the fiscal memory of each printer the serial number and unique number. The numbers are visible outside the printer and are entered into 'The fiscal cash register service book' attached to the printer.

The fact of fiscalization of the fiscal printer is registered in the service log. The saving to the fiscal memory is held during closing of the fiscal day. In the process of closing of the fiscal day, apart from the saving to the fiscal memory, the information appears additionally as the printout 'Daily fiscal report'. They may always be reproduced in the form of the printout 'Periodical fiscal report'.

Transmission of data to CRK is in accordance with the schedule. The representative of the competent authority of the Ministry of Finance has the right to inspect the information sent by the printer in real-time with the data already saved in the system and remote setting a new schedule of operation of the cash register and certain settings, e.g. QR code printing. The printer is equipped with a battery and mains power system, thanks to which, in the event of a failure of the mains supply, the sales may be continued. Regulations concerning the fiscal printers, explicitly specify the standards of emergency power supply. Battery supply of the cash register enables the printout of at least 200 fiscal and non-fiscal documents with the total length of at least 6000 lines after 48 hours from disconnection of external supply, excluding transmission of data (the Polish journal of laws: Dz.U. 2018 poz. 1206 § 16.1).

1.5. DAILY FISCAL REPORT AND PERIODICAL FISCAL REPORT

When the sales for a particular day is ended, no later however than before the first sales on the following day, one should emit the daily fiscal report. It includes the summary data on turnover and amounts of tax for a particular day, included in all fiscal receipts and invoices printed by the printer during the day, divided into the particular tax rates and sales exempt of tax, as well as receipts and invoices. The report is not required if on the given day, sales being subject to recording by the fiscal printer has not taken place. The tax payer is not required to print paper original report, electronic version of the document is enough. The printer, in the default mode of operation, attempts to connect with CRK and transfers data saved in the memory no less frequently than every 2 hours or at the user's request.

Tax payers are also obliged to prepare printouts of periodical reports for monthly periods – after ending on the last day of the month. In case of need, periodical reports for selected by the user period may also be printed. Periodical fiscal reports constitute the sequence of proper daily fiscal reports and their electronic copy is not saved in the printer's protected memory or transferred to CRK.

Fiscal printers are accounting devices which allow the tax payers to record only part of the achieved VAT turnover, therefore many tax payers are obliged also to keep other accounting documents.



Exorigo-Upos Sp. z o.o.
ul. Kolejowa 5/7, 01-217 Warszawa
Biuro w Gliwicach
44-100 Gliwice
ul. Bajkowska 35
NIP 9261838767

nr wydr. 000066

RAPORT FISKALNY DOBOWY

000010

Od: 13.06.2018 10:07
Do: 13.06.2018 10:10

PTU A 23,00 %
PTU B 8,00 %
PTU C 5,00 %
PTU D 0,00 %
PTU E --,--
PTU F --,--
G SP.ZW

SPRZEDAŻ OPOD. PTU A	7611,22
SPRZEDAŻ OPOD. PTU B	9633,33
SPRZEDAŻ OPOD. PTU C	6012,38
SPRZEDAŻ OPOD. PTU D	720,00
SPRZEDAŻ OPOD. PTU AFU	9,27
SPRZEDAŻ OPOD. PTU BFU	133,33
SPRZEDAŻ OPOD. PTU CFU	0,00
SPRZEDAŻ OPOD. PTU DFU	0,00
SP.ZW PTU G	1944,00
SP.ZW PTU GFU	0,00
KWOTA PODATKU PTU A	1750,58
KWOTA PODATKU PTU B	770,67
KWOTA PODATKU PTU C	300,62
KWOTA PODATKU PTU D	0,00
KWOTA PODATKU PTU AFU	2,13
KWOTA PODATKU PTU BFU	10,67
KWOTA PODATKU PTU CFU	0,00
KWOTA PODATKU PTU DFU	0,00
ŁĄCZNA KWOTA PTU	2834,67
ŁĄCZNA NALEŻNOŚĆ	28898,20

WALUTA EWIDENCYJNA:	PLN
---------------------	-----

ZDARZENIA	
SYTUACJE AWARYJNE	000001
PROGRAMOWANIE:	
L	000003
O	000000

ZMIANY W BAZIE:	000011
-----------------	--------

PARAGONY	000007
FAKTURY	000003
PARAGONY ANULOWANE	000008
	15046,00
FAKTURY ANULOWANE	000000
	0,00
DOKUMENTY NIEFISKALNE	000007

#001 Jan Kowalski
2018-06-13 10:10

07D043DF3A78D1AD63EC1209827465D37288CFFB

ZAE1801000105

Optional graphics

Name of the tax payer

Address of the sales point

Following number of printout

Designation of the daily fiscal report

Number of the fiscal day

Duration of the particular fiscal day

Definition of the goods and services tax rate

Amount of net sales divided into particular goods and services tax rates for receipts

Amount of net sales divided into particular goods and services tax rates for invoices

Tax due for receipts

Tax due for invoices

Total amount of goods and services tax

Total gross amount

Recording currency

Number of registered emergency events

Events related to software:

L-conducted by the user or service; O-online

Number of changes of the commodity base

Number of issued receipts and invoices

Number of cancelled receipts and invoices

Number of issued non-fiscal documents

ID of the cash register and ID of the cashier

Date and time of ending the daily report

SHA2 abbreviation

Fiscal logo and unique number of the cash register

Exemplary printout of the Daily Report

Important:

Note that the Daily report is printed automatically during closing the period called the Fiscal Day and such manner of receiving the printout should not be treated as the manner of settlement of internal periods, e.g. particular changes within the calendar day. Settlement of internal periods may be conducted in the form of other reports, but it does not have to narrow the scope of fiscal day and unnecessarily take up a part of fiscal memory. One may use the periodical fiscal report or non-fiscal x report, then.

1.6. REACHING THE CAPACITY OF THE FISCAL MEMORY

Fiscal memory used in the fiscal printer allows to save 2,100 daily records. The information on reaching the capacity of the daily reports' saving in the fiscal memory appears from the 2,070th day:

```
Exorigo-Upos Sp. z o.o.  
44-100 Gliwice  
Bojkowska 35/21  
NIP 9281838767  
nr wydr. 000011/2078  
NIEFISKALNY  
KOMUNIKAT SYSTEMOWY  
UWAGA: Pamięć fiskalna prawie pełna!  
Zostało miejsca na 23 rekordy fiskalnych  
dobawych.  
NIEFISKALNY  
#001 Jan Kowalski  
2018-07-06 12:57  
221FF652AB9D68DCCAB760C6586336888C199B30  
ZAE1801000104
```

At the 2,100th record, the printer automatically switches into the read-only mode and starts to make a steady sound.

1.7. TERMS OF PRINTING VAT INVOICES

Principles applicable to printing VAT invoices:

- it is not possible to grant increase up to the sales line as during printout of a receipt but it is possible to give discount, offer reduction or their correction.
- in the course of the sales, it is not possible to cancel the sales of a single article, only the whole invoice.
- each invoice may be cancelled in any moment during the sales but no later than before its ending.
- the seller's obligations include controlling the condition of paper in the station and the assessment of correctness and quality of print, original and copy of the invoice.

Issue of invoices in the receipts' station is subject to the following technical limitations:

Paper:

- The invoice is printed on the paper roll. It is a one-layer, thermal paper.

Cancelling an invoice:

- The invoice will automatically be cancelled after 30 minutes from the start of sales.

Failure of power supply:

- When the failure of power supply ends, the printer resumes printing an invoice which then may be completed.

2 CONSTRUCTION OF THE FISCAL PRINTER

The fiscal printer is built of an "easy load" thermal printing mechanism equipped with an automatic cutter, a customer display in an integrated version with the printer, with a standard or extended mast, battery power supply, electronic packages, including fiscal memory and protected memory from any outside interference, TPM cryptographic module in 2.0 standard.

The display is in the version: alphanumeric LCD 2x20 (integrated or free-standing) or OLED 3.12" (external, built-in).

2.1. BASIC ELEMENTS

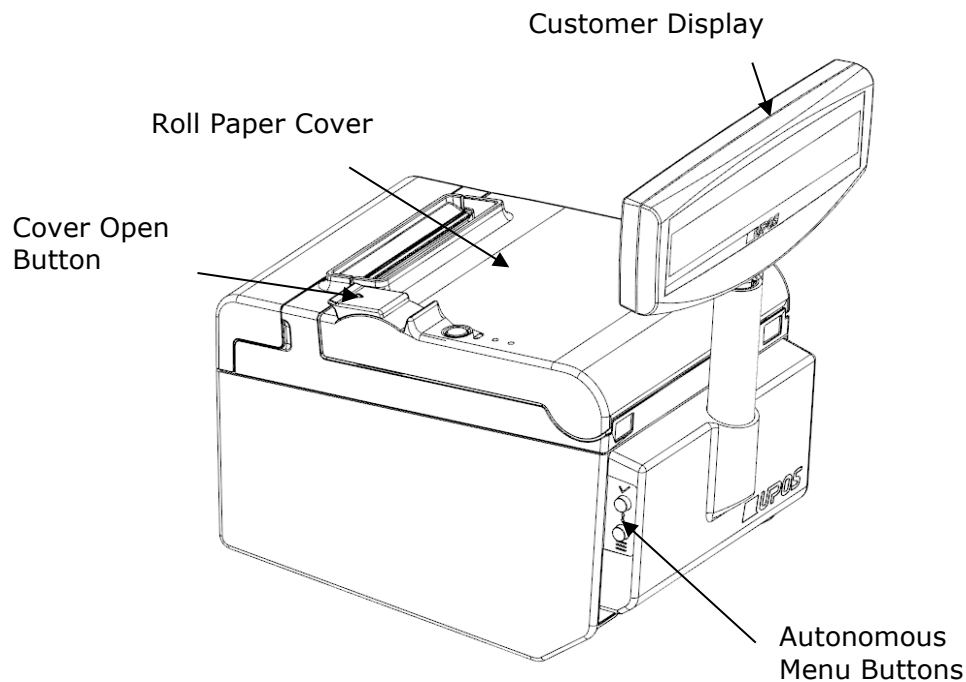

2.2. SIZING

The device's dimensions are provided in millimeter and include two customer display mast lengths.

Version with integrated display.

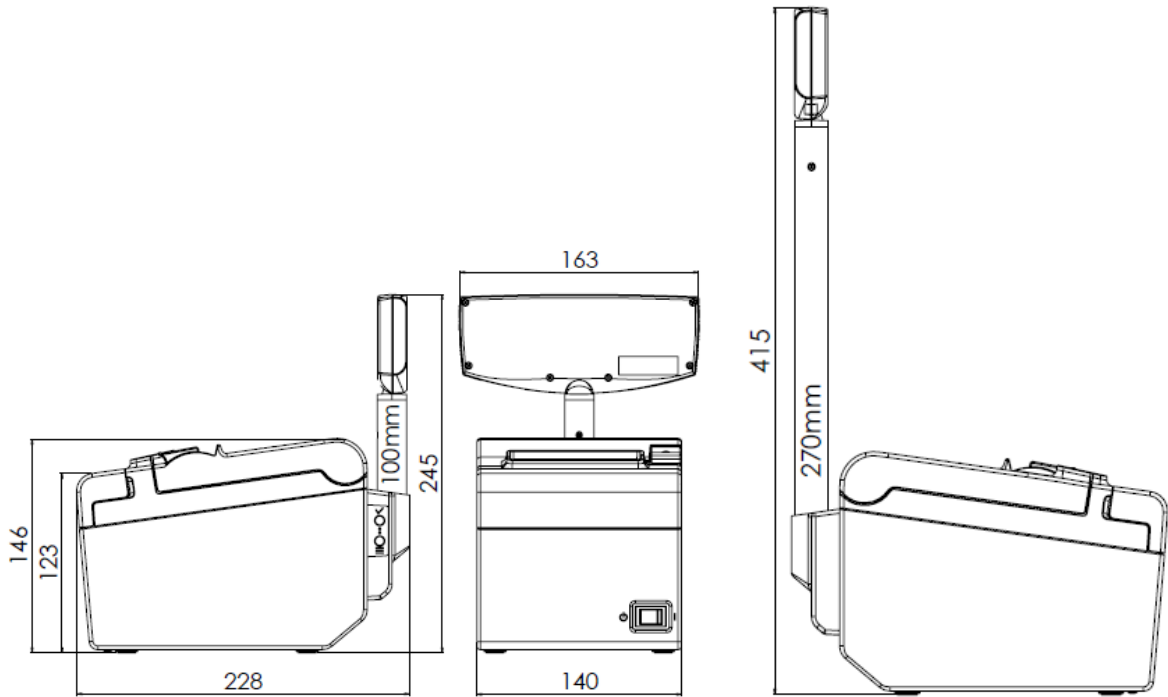

Version with external, free-standing display.

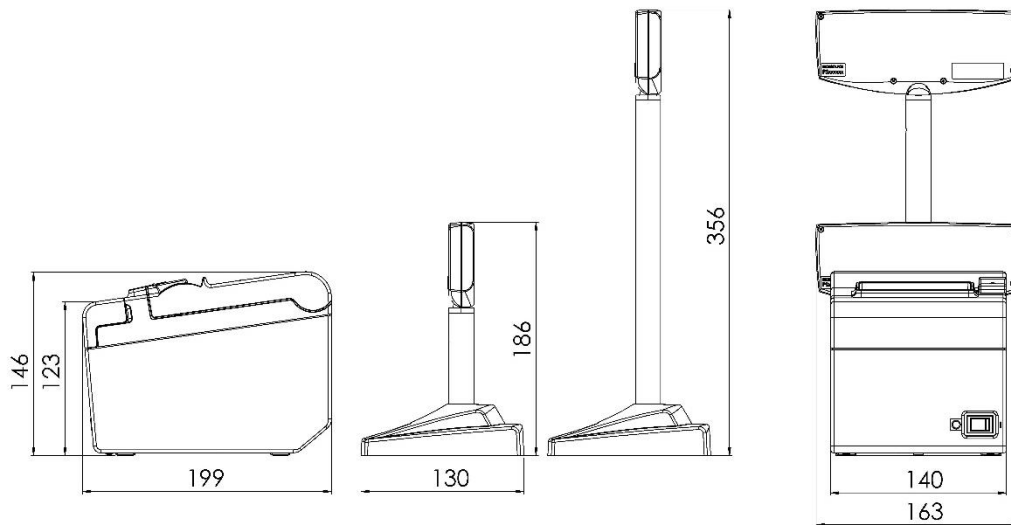

It is also available, a built-in version with an external display.

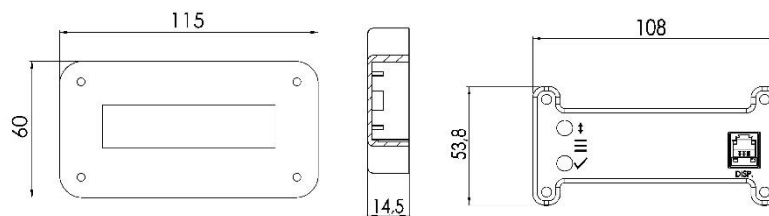

2.3. INTERFACE CONNECTORS

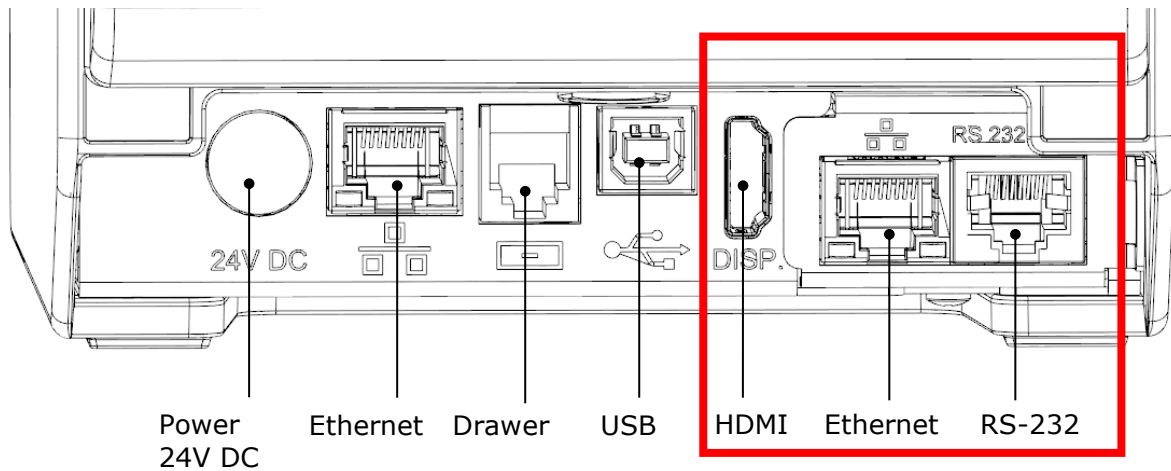

Connectors marked with a frame appear depending on the fiscal printer configuration. It is possible that the user will not have an additional Ethernet or HDMI connector.

Ethernet connector

This connector is installed as standard, in every configuration of the fiscal printer UPOS-FP20 ONLINE. This is an Ethernet interface, working in the IEEE 802.3 100BASE-TX standard. The additional connector is construction option and can be used as 100BASE-TX.

Type: standard T568-B
Socket: 8P8C – RJ-45

HDMI connector

The HDMI connector is reserved for connecting a free-standing display and is not available in the printer with an integrated display.

Drawer connector

The printer is equipped with a signal interface to drawer connection. Opening the drawer, reading the status and set pulse parameters of drawer are functions supported by the printer's communication interface. The printer has the option of changing the drawer opening voltage for values: 5/6/12/24 V, and allows for connecting to the most usage drawers on the market.

Socket: Type RJ-12

Pin #	Description
1	Protective GND
2	Drawer opening signal 1 (max 1A DC) (GND – if active)
3	Drawer state: Open / Close (GND – drawer is open)
4	Keying + 24VDC
5	Drawer opening signal 2 (max 1A DC) (GND – if active)
6	Signal GND

RS-232 connector

The printer has a serial interface RS-232, compatible with the EIA/TIA-561 standard.

Type: RS-232

Socket: Type RJ-45

Pin #	Designator	Description
1	DSR	Data Set Ready
2	DCD	Data Carrier Detected
3	DTR	Data Terminal Ready
4	GND	Signal Ground
5	RxD	Receive Data
6	TxD	Transmit Data
7	CTS	Clear to Send Data
8	RTS	Request to Send Data

USB connector

Type: B

Socket: USB

Pin #	Designator	Description
1	V _{BUS}	+5 V
2	D-	Data-
3	D+	Data+
4	GND	Ground

2.4. CONTROL PANEL

Location of buttons on the printer cover.

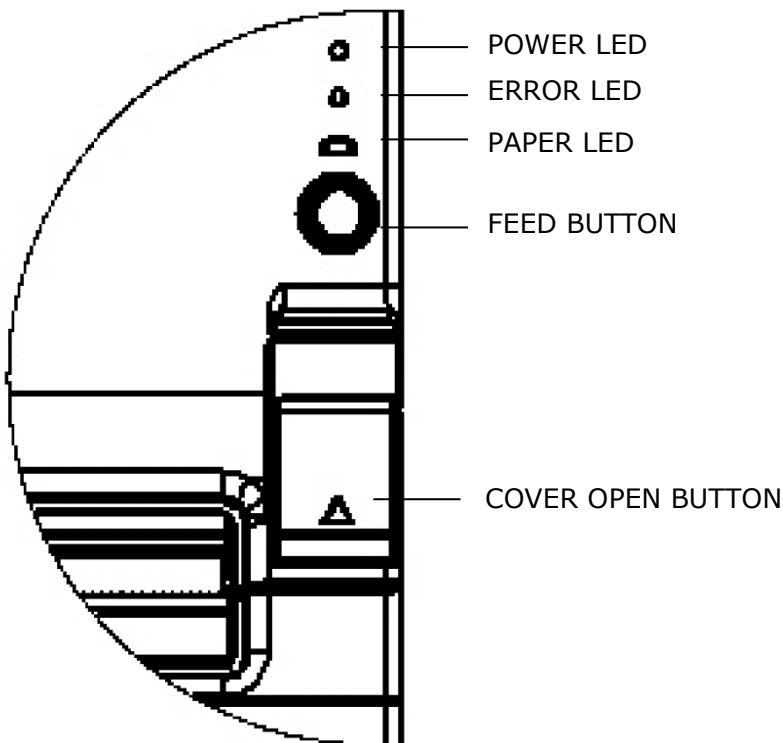

Location of Autonomous Menu buttons.

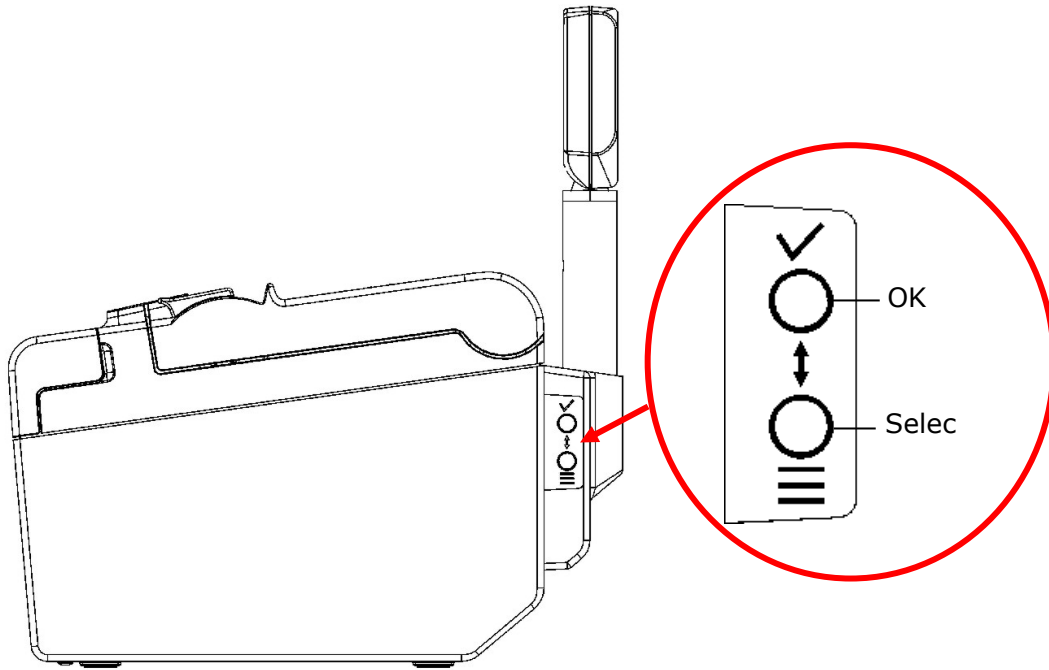





The LEDs on the top receipt cover indicate the status of the printer. Below is the description of the individual signals and buttons.

Operating Panel of the Printer Mechanism:

LED DIODE:	COLOR:	SIGNAL:	DESCRIPTION:
POWER	Green	Light	The Printer is ON.
ERROR	Red	Light or Blink	The Printer is not ready to work.
		Light	Receipt cover is open. Paper is out.
		Blink	Printer error is occurred, so check paper and reset device.
PAPER	Red	Light	The roll paper end or near the end.

Buttons:

- 
FEED BUTTON – use to feed paper, inactive when the paper cover is open, the end of the paper is detected, or the button has been disabled by software (e.g. when receipt is open).
- 
COVER OPEN BUTTON – use to open receipt cover to load roll paper.
- 
OK – use to confirm changes in the autonomous menu (chapter 5).
- 
Select – use to switching functions in the autonomous menu (chapter 5).

The location of the autonomous menu buttons on the free-standing display is shown below.

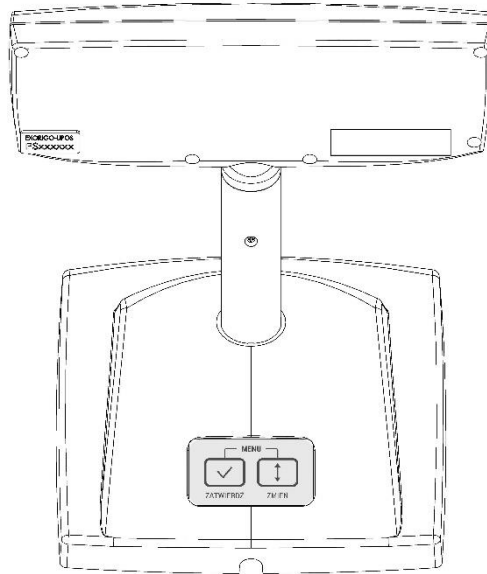

3 UNPACKING AND PREPARING FOR WORK

NOTE!

Unpacking and preparing the printer for work may be held only by the authorized service provider.

The printer, together with the computer which it is connected with, should be supplied with power from sockets of the same phase of mains voltage.

Connecting devices should be held when the power is off.

Before starting sales, it is recommended to connect the printer with the power source for 24 hours in order to charge batteries.

Storage and transport of the printer should be held in the special packaging.

3.1. COMPOSITION OF THE PACKAGING

The printer's packaging should include:

1. USB A-B cable (optional)
2. Communication cable RS-232 type RJ45
3. Epson PS-180 24V, 2.1A power supply with the network cable
4. Start paper 80 mm
5. Cash register book
6. Warranty card with the implementation card for the client and manufacturer
7. Fiscal printer with integrated customer display.

3.2. CONNECTING THE PRINTER WITH THE COMPUTER

The fiscal printer UPOS-FP20 ONLINE may be connected with the computer through the interfaces:

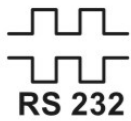

RS-232 (serial port)



USB (virtual serial port)

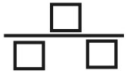

Ethernet

Work with the printer is possible only upon its detection by the appropriate cash register's application (adjusted to the printer's functionality).

Connection of the printer with the computer through the USB port may require installation of a driver which is available on the printer manufacturer's website. The USB cable is attached to the printer at the customer's request. Please, use only the manufacturer's cable.

Using the Ethernet connector, the printer should be connected to the same network as the computer with installed cash register application.

If you have a fiscal printer in a configuration with 2 Ethernet ports, the other can be used as a switch.

3.3. DRIVERS, SOFTWARE, INSTRUCTIONS, CERTIFICATES

On the devices' manufacturer's website <https://www.exorigo-upos.pl/urzadzenia/drukarka-fiskalna-upos-fp-20-online/> there are available: software, instructions and certificates.

3.4. INSTALATION REQUIREMENTS

The device may operate in average, non-air-conditioned rooms, without air filtration. One should avoid places exposed to significant temperature variations, high insolation, large quantities of dust, vibrations and strokes. The device should not be installed in the rooms with highly aggressive corrosive environment and in rooms where water vapor condensation occurs.

The fiscal law requires providing with a stable internet connection.

Ambient climate conditions

Temperature	5 ± 45°C
Humidity	10 ± 90%

3.5. SELECTION OF THE WORKPLACE OF THE FISCAL PRINTER

Notes regarding the selection of the workplace:

- the printer can be positioned
 - horizontally regardless of the design version,

- vertically for the version with a free-standing display or external to be built-in,
- the device may work up to 2000 m ASL,
- using the printer in the place with high humidity and exposed to electrostatic discharge should be avoided,
- using the printer in the place with too high or too low temperature should be avoided,
- the printer should not be exposed to intensive sunlight,
- the printer should not be used or stored in dusted or dirty places,
- no foreign materials or liquids may be let in the device,
- the printer should be placed on a firm surface, intensive vibrations or shocks may damage it,
- the printer should be surrounded by sufficient space around it so that the service actions could be easily conducted,

the devices cooperating with the printer should have the CE mark.

3.6. BASIC PRINCIPLES OF THE PRINTER'S OPERATION

At the operation of the device:

- never pull the paper hanging out of the printer when the printer mechanism is closed,
- the heating element of the printing head and its sliding mechanism may be damaged easily in contact with any metal object, therefore they must be protected, as appropriate,
- the printing head and its direct neighborhood become strongly heated, they should never be touched while printing and right after,
- the printing mechanism should be never opened while printing,
- the surface of the printing head should be never touched, as smudging it may affect the heating element negatively,
- only paper corresponding with the specification should be used, as thermal paper containing sodium, potassium, chlorine or other ions may affect the heating element negatively,
- using the printer in highly dusted or dirty conditions will cause reduction of the printing head's life span,
- one should not allow the vapor condensation inside the printer and in such event, the device should be opened before switching on and one should wait until the water evaporates,
- for avoiding a paper jam, one should neither cover with his/her hand the opening where the receipts go out, nor place any objects in front of it,
- the device may be plugged only to the power supply indicated in the manual instruction, it is not allowed to make any changes independently on the power supply cable,
- if the printer has been damaged, it should be unplugged from the power supply – taking off the plug from the socket; one should always pull the plug, not the cable,
- it is not allowed to disassemble the printer's elements independently, as an electric shock may occur – only authorized service provider has the right to the justified disassembly,
- the waste paper core should be disposed of in compliance with the local regulations,
- at the device's disassembly, the plug should be plugged off the network socket first and one should be careful not to damage the power supply cable,
- the printer should not be used when the paper is not placed properly (the manner of replacement of paper is shown in the further part of this manual instruction),

the correct size of the paper roll has influence on proper loading paper and avoiding paper jams.

4 OPERATION OF THE FISCAL PRINTER



Only unplugging the power supply cable results in full disconnection of power from the device.

Before connecting the device with electric network 230 V AC, it should be checked whether the power supply cable has not been damaged and the network socket should be in an easily accessible place.

4.1. STARTING THE PRINTER

Only original power supply delivered with the printer should be used for supplying the printer. It is an external power supply 24V DC, made in the 1st insulation class. The power supply's plug must be connected with the socket by an earthing pin. In order to start the printer:

1. Please check, whether the power supply's plug is disconnected with the electric network 230V.
2. Connect the power supply's plug with the socket in the printer.
3. Plug the power supply's plug into the 230 V (AC) socket.
4. Turn the switch on the right side of the printer into the proper.

Disconnecting the printer from the power supply or failure of the power source, causes the printer to automatically switch to battery operation.

If the printer is in standby mode, hold down one of the autonomous buttons for about 1 second.

NOTE!

Electric socket where the power supply is plugged to, must be located in the vicinity of the device and easily accessible.

If the printer has been at a temperature below -10 ° C, please wait 2 to 3 hours when the printer temperature take the ambient temperature.

4.2. OPERATION ON THE BATTERY

The fiscal printer, despite having its own battery, should work with permanently switched on external power supply.

No external power supply due to disconnecting the printer from the electric network or failure of the power supply source, cause automatically switching the printer into the battery power supply. If the printer is not performing any operations (no user's or interface's activity), then the printer enters into sleep mode and after approx. 5 minutes the printer is fully switched off. In the sleep mode, the client's display is switched off. When the printer receives an order through the serial interface, the display is switched on and normal operation mode is resumed. When the battery is discharged, the printer is completely switched off. Therefore, it is recommended to complete sales and close the fiscal day before the battery power supply is switched off. After restoring the mains power supply, the printer starts automatically and the operation will be resumed. In that time, the battery is also charged.

NOTE!

Charging batteries is possible only when the printer is plugged into the 230 V (AC) network .

One should not let the battery become completely discharged, as duration of full charging lasts approx. 24 hours. It is recommended to turn on external power supply even when the printer is not used or when it is switched off.

NOTE!

The device includes the lithium battery, type CR1220 and the accumulator battery Li-Ion, type MPL 10.8/2.3A/Li-Ion. The battery should be used only in accordance with its intended use. Improper dealing with the battery may cause fire, explosion or occurrence of other threats.

4.3. SWITCHING OFF THE PRINTER

In order to switch off the printer, the below instructions should be followed.

1. Move the switch on the right side of the printer into appropriate position.
2. Switch off the power supply from the printer, taking off the plug from the 230 V AC socket.

NOTE!

In order to switch off completely the power supply from the printer, the plug should be taken off the 230 V (AC) socket.

4.4. CONNECTING THE PRINTER WITH THE COMPUTER

In order to connect the printer with the computer, the following actions should be taken.

1. Switch off the printer and computer.
2. Plug the computer to the proper printer's socket (RS-232), with use of appropriate communication cable.

NOTE!

The length of the communication cable should not exceed 2.5 [m]. Use only the original cable delivered with the printer in order to connect the printer with the computer.

When using cables which are not dedicated by the manufacturer, electromagnetic disturbances may occur which may damage the device.

4.5. INSERTING THE PAPER ROLL

NOTE!

During the printer's operation, the printing mechanism must be closed. The elements of the cutting edge of the paper cutter may not be touched in order to not to get hurt.

Only paper recommended by the manufacturer, not glued to the paper core should be used.

Replacement of paper may be conducted with the printer switched on or switched off. Before loading a new roll of paper, first rotate the customer display to allow free access to the inside of the printer (in the case of integrated display), and then do the following:

1. Move receipt cover open button.
2. Open the receipt cover to the maximum position and insert the roll so that the paper unwinds from the bottom.

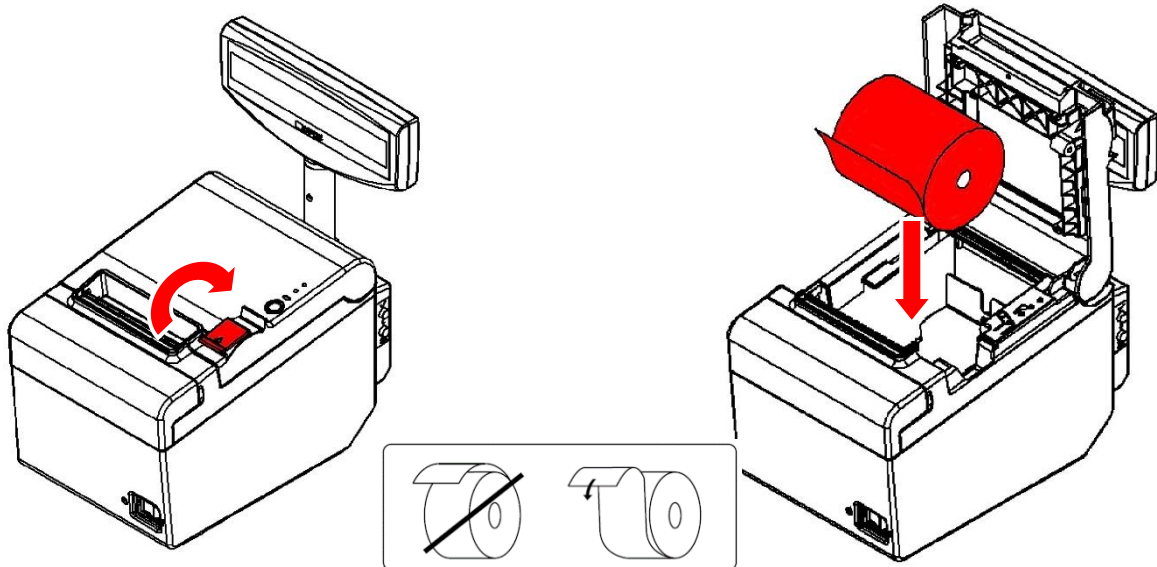

3. Snap the cover shut while holding the end of the paper out.
4. Tear off the protruding piece of paper using the notched edge in the printer.

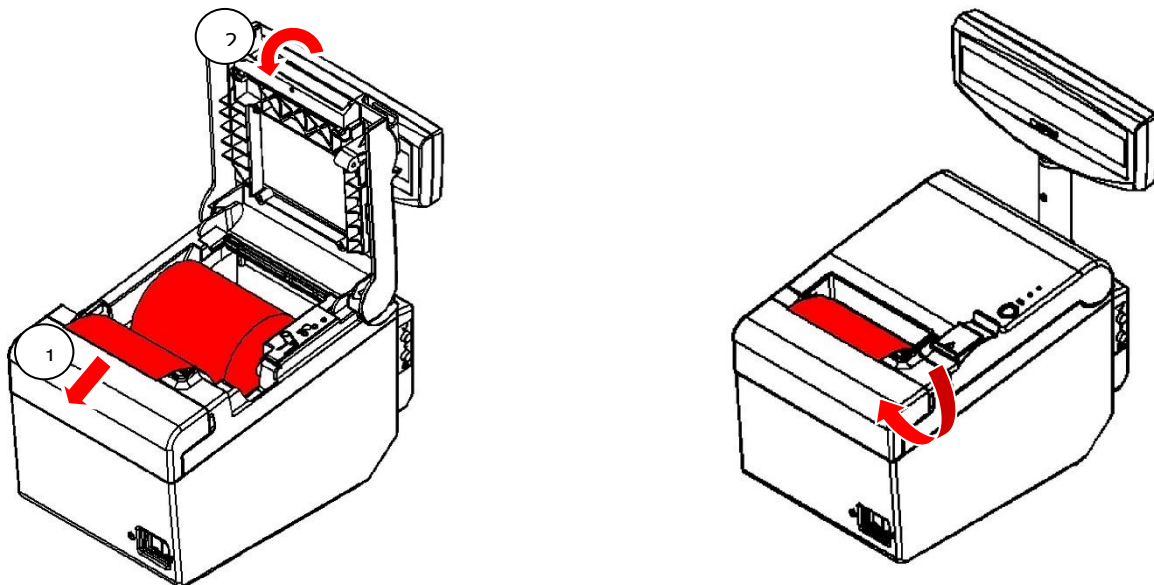

In the event of replacement of a roll into a new one, note that the remaining of the waste paper roll should be removed.

4.6. SERVICE ACTIONS

The printer requires periodical maintenance and once every two years, the service inspection. Systematic maintenance of the device guarantees longer reliability of the device. Recommended maintenance procedures should be performed no less frequently than once a year, although it depends on the environment of the device's operation (e.g. at higher dusting, the printer should be subject to service maintenance more often). Failure

to conduct the activities may even lead to damage of the printer due to user's fault and result in loss of warranty. And in the event of failure to conduct the service inspection, the user is exposed to sever financial consequences. For the service technician's arrival, the user should prepare the cash register book each time.

Thorough maintenance of the device is carried out by a service technician, however some basic operations can be carried out by the user.

To clean the cover of the printer, use a cotton cloth slightly moistened with water or dry. Do not use products containing alcohol, benzine, thinner or thinne.

Cleaning the thermal head and impression roller.

Dust and pieces of paper may stick to the heating element of the printing head or the impression roller, which affects negatively the quality of print. In such case, the printing head and roller should be cleaned in the following way:

1. Switch off the power supply.
2. Open receipt cover.
3. Wipe the heating element of the printing lever and then the impression roller with the use of a cotton pad soaked with ethyl or isopropyl alcohol. Do not touch the heating element with anything else than the pad.

NOTE!
Never clean the printer right after printing, as the heating element is very hot then!
Before cleaning, the printer must be switched off!
Please wait, until the alcohol has evaporated after cleaning.
When cleaning the device yourself, be careful not to damage the printer seals.

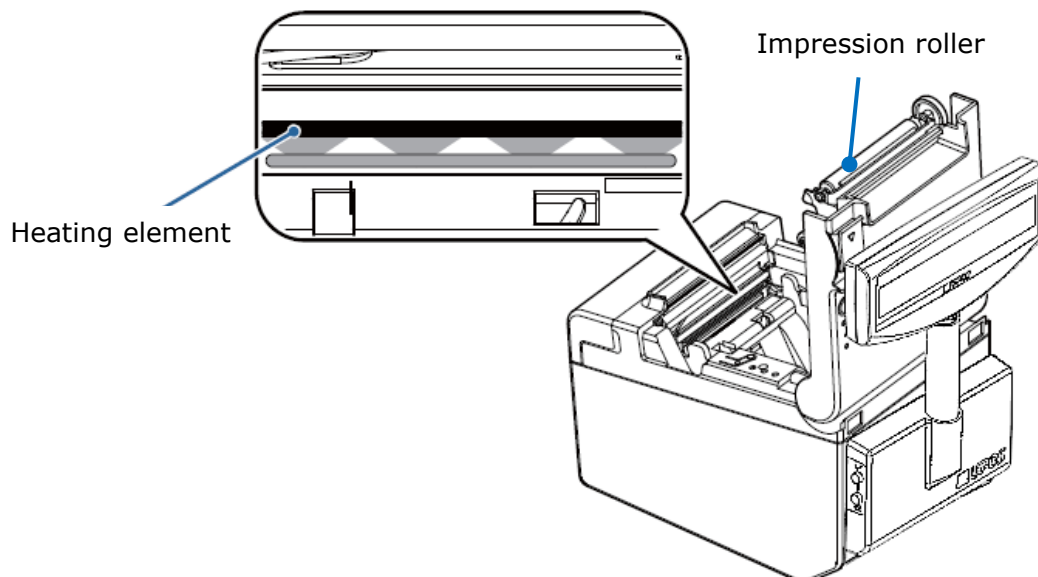

Procedure of removal of the paper jam

1. Switch off the printer.
2. Open receipt cover by open cover button.
3. Remove the paper jam and install the roll again.

Procedure of removal of jam of the cutting edge of the paper cutter

1. Switch off the printer.
2. Open the cutter cover.

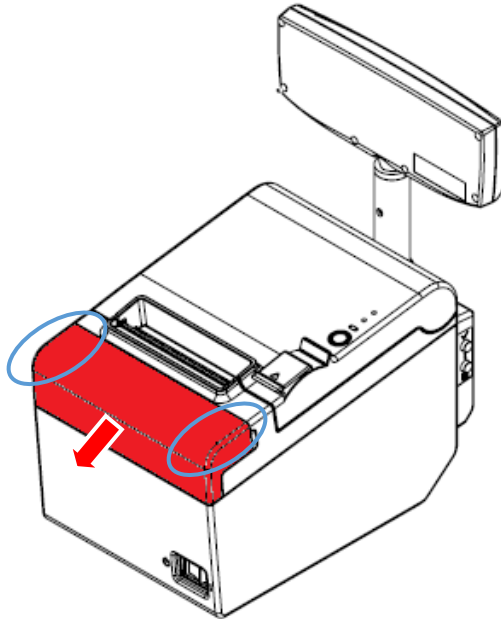

3. Turn the knob in the direction of the arrow until the triangle symbol appears in the window.

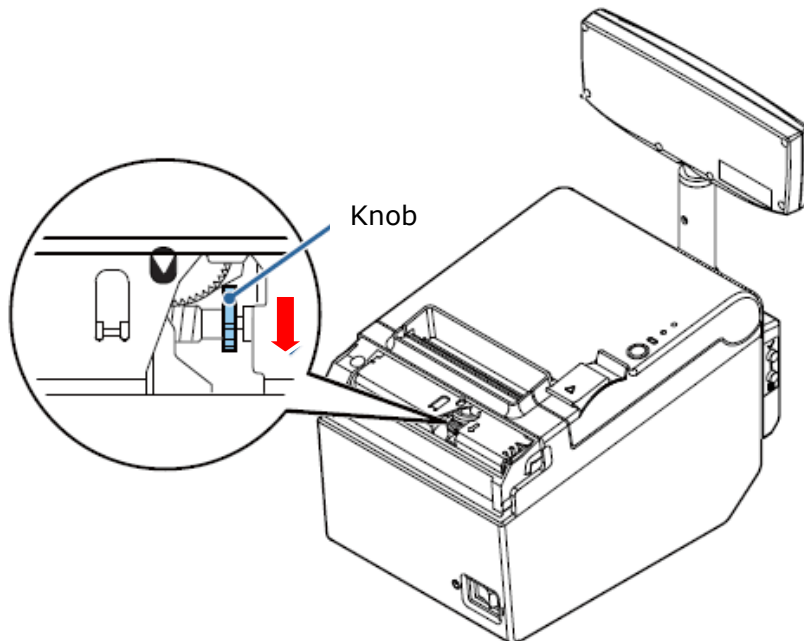

4. Tear off any jammed paper.
5. Close the cutter cover and start the printer.

4.7. CUSTOMER DISPLAY

The UPOS-FP20 ONLINE printer is equipped with a customer display, which shows the current state of the printer.

The display is an integral part of the fiscal printer and performs the following functions:

- providing the buyer with a good / service reading the value of the sale transaction,

- reading the cash register work program version,
- informing about the course of some processes,
- displaying information about errors,
- provides support for the autonomous menu,
- enables the display of non-sales advertising content if no sales operations are being performed and no error messages are displayed. Alternatively, the current time and date are displayed.

Each failure of the display is connected with the ability of the printer's operation being stopped and it prevents from conducting further sales. Because the display's construction makes it sensitive to misuse, it is important to follow a few basic rules. While using the display, a few basic principles should be observed:

- The display has a rotation limiter that protects the cables against damage (twisting them); never turn the display by forcing, because the turn limiter can be damaged,
- Place the printer on a stable, flat surface,
- The display should be set in face side to the customer,
- Do not move the printer by the mast.

4.8. UPDATE FIRMWARE

The firmware can be updated by the manufacturer. The user will be notified by the printer about the appearance of a new update. The update firmware can start only after the fiscal day is closed. In the first step, the printer checks the availability of a new version of the firmware and verifies the approval status on the CPD servers. If the verification returns a positive response, the printer connects to the update server and starts downloading the new version of the firmware.

During the update process, the following information appear at the customer display:

- verification of availability of the new firmware
- new firmware is available
- downloading the new firmware
- successful update of the firmware.

The process of update lasts approximately 45 minutes. When the update operation has been correct, the user will receive the confirmation in the form of a printout and the printer restarts automatically. In the event of unsuccessful update, it is possible to repeat the process only after the following closing of the fiscal day.

5 AUTONOMOUS MENU

In the fiscal printer's operation software, there is implemented a user's interface in the form of the menu displayed on the client's display. Menu allows the operator to perform certain functions which usually are activated through the software interface, as for example performing the Daily Report or making service tests or change of settings of the printer's parameters.

5.1. MENU OPERATION WITH USE OF PRINTER'S KEYS

To control the printer from the menu, in the autonomic operation mode, there are used the following keys: ✓ and ↓

Entry into the Menu

Holding both keys for a few seconds until a sound is heard

Exit from the Menu	Selection of the order 'END MENU' causes leaving the autonomic mode
„CHANGE” key ↕	Pushing the button causes moving to the following item of the menu or change of the set value of the parameter.
„CONFIRM” key ✓	Pushing the button causes entry to the menu options or performing a selected function.

From the level of the menu it is possible to select the ready printouts or such, where a specific numeric value should be entered first. At the entry of specific digits, one should confirm the selected value with the ✓ button each time in order to move the cursor of selection to the following item, e.g. if you want to enter a 3-digit number, the thousandth digit should be set first, after its approval, the tenth digit should be set and after its approval – the unity digit should be set. The numeric values are limited by the proper range which prevents the user from selecting improper value.

The user may select the numbers from 0 to maximum value from the given range.

Holding the button ✓ for approximately 2 seconds, in the course of setting the numeric value:

- if the selection cursor is placed on the last digit (unity) – return to the position of the first numeric value will occur, enabling to enter the values again.
- If the selection cursor is placed on the first significant digit of a given value – switch into the menu will occur.

It is impossible to enter to the printer's autonomic menu when the fiscal printout is open.

5.2. MENU STRUCTURE

Configuration menu consists of three items, in which printer's functions are sorted, as appropriate.

Menu konfiguracyjne >

Raporty finansowe >

Raport dobowy

Raport X

Raport okresowy >

Raport okresowy szczegółowy >

Od numeru do numeru

Od daty do daty

Miesięczny

Pełny zakres

Wróć wyżej ^

Raport okresowy łączny >

Od numeru do numeru

Od daty do daty

Miesięczny

Pełny zakres

Wróć wyżej ^

Wróć wyżej ^

Wróć wyżej ^

Inne raporty >

Raport informacyjny

Raport zdarzeń

Raport interwencji

Raport towarów zablokowanych

Wróć wyżej ^

Wyślij do CREJ >

Konfiguracja >

Interfejsy >

RS-232C-A

Trans.: 115200 N 8 2

9600 0 1

19200 E

28800

38400

57600

Handshake

Programowe

Sprzętowe

Wróć wyżej ^

Obcinacz

Opcja

Cięcie

Wróć wyżej ^

Wydruki

Odstęp linii

Normalny

Zagęszczony

Anulowanie wydruku po włączeniu zasilania

Nie

Tak

Wróć wyżej ^

Sieć

Adres

DHCP włączony:

Tak

Nie

IP

Maska

Brama

Preferowany DNS

Alternatywny DNS

Wróć wyżej ^

Wróć wyżej ^

Strona kodowa

Aktualna: 852

852

1250

MAZOVIA

ISO8859-2

Wróć wyżej ^

Wróć wyżej ^

Beeper

Aktualnie: wyłączony	
	włącz
	wyłącz
	Wróć wyżej ^
Wróć wyżej ^	
Uruchamianie	
Weryfikacja pamięci chronionej: Tak/Nie	
	włącz
	wyłącz
	Wróć wyżej ^
Wróć wyżej ^	
Wróć wyżej ^	
Zapis zmian:	
	TAK
	NIE
ZAKOŃCZ MENU	

Item of the menu	Description
Raporty finansowe	Enables to print the fiscal reports (daily and periodical detailed) and collective periodical reports.
Inne raporty	Enables to print non-fiscal information reports, service reports and reports of events.
Konfiguracja	Enables to change certain configuration parameters of the printer, e.g. speed of data transmission between the printer and the computer, code page of diacritic signs, switching on and switching off the cutter and the sound.
Wyślij do CREJ	An additional option, that allows sending data from protected memory to CREJ (Central Repository Electronic Journal).
<i>Weryfikacja pamięci chronionej</i>	Enables to verify the protected memory at the request. If in the printer's autonomic menu, the option of verification of the protected memory has been switched on, then at each starting the printer, at the client's display there appears the question, whether the verification of the protected memory should be started. The selection is made with use of the autonomic menu's keys. If the user does not make the selection, then after approx. 10 seconds, the printer will start without verification.

5.3. DAILY REPORT

In order to produce the daily report from the level of the printer's menu, one should:

1. Enter the autonomic menu by holding both keys on the panel on the side of the printer until a sound is heard.
2. Select the first item 'Financial reports' with the button ✓.
3. Select the first item 'Daily report' with the button ✓.

Producing the daily report results in saving a relevant record in the fiscal memory in appropriate VAT rates from the given fiscal day.

5.4. PERIODICAL REPORT

In order to produce the periodical report from the printer's level, one should:

1. Enter the autonomic menu by holding both keys on the panel on the side of the printer until a sound is heard.
2. Select the first item 'Financial reports' with the button ✓.
3. Select the third item 'Periodical report' with the button ✓.
4. Select between the item 'Periodical detailed report'.
5. Select the required manner of printing:
 - a. from the first number of the daily fiscal report of the user's interest until the last one - 'From number to number'
 - b. printout of scope of daily fiscal reports from specific time period - 'From date to date'
 - c. printout of all daily reports of a particular, specific and ended month - 'Monthly'
 - d. printout of all daily reports from producing of the first daily report - 'Full scope'.

Fiscal periodical detailed report is produced by reading the saved fiscal data from the fiscal memory at the request of the user of the time period and printing them in accordance with each single daily report, as to the content. If in the given period there was no sales and registration of turnover, then the report will not be printed and there will be printed the inscription 'No record in the given period'.

Summary periodical report is a non-fiscal printout constituting the summary of total turnover divided into the specific tax rates and in their duration for the particular period based on the fiscal daily reports.

6 TECHNICAL SPECIFICATIONS

6.1. SPECIFICATIONS OF THE APPLIED PAPER

Paper parameters

Type	Thermal, one-layer, in rolls
Width of the roll	80 mm
Maximum diameter of the roll	83 mm
Diameter of the paper core	int.: 12 mm, ext.: 18 mm

Examples of paper types:

- TF50KS-E, TF60KS-E (NIPPON Paper Industries Co., Ltd.)
- PD160R, PD190R (OJI Paper Mfg. Co., Ltd.)
- P220AGB-1 (Mitsubishi Paper Mills Limited)
- P35024 (Kanzaki Specialty Papers)
- AF50KS-E (Jujo Thermal Oy)
- F5041 (Mitsubishi HiTec Paper Flensburg GmbH)
- KT48FA ,KT55FA (Koehler Paper Group).

Changing the width of the paper requires ordering from the manufacturer a special reducer and the service technician setting the appropriate configuration data in the printer's firmware.

NOTE!

The paper roll must be inserted into the printer so that, it unwinds from below.

Paper cannot be glued to the inner roll or folded around the plastic roll. Store unused paper rolls in the original, manufacturer-labeled packaging in accordance with the warranty conditions.

The expiry date and thus the period of the print quality guaranteed by the paper manufacturer and the way the printouts should be stored should be specified by its manufacturer.

6.2. PRINTER'S PARAMETERS

Mechanic specifications	Construction:	compact, free-standing
	Dimensions:	height x width x length [mm]
	Mechanism:	144 x 199 x 147
	with integrated display:	146 x 228 x 245 (standard mast) 146 x 228 x 415 (mast - option)
	Weight:	
	Integrated set:	2, 4 kg (without paper)

Electric specifications	Type of power supply:	mains – battery, external power, supply +24V DC, 2.1A
	Voltage:	24V DC
	Power consumption:	
	Maximum:	48 W
	Typical:	33 W
	Standby:	5 W

Conditions of operation and storage	Temperature:	
	of operation:	5° - +45°C
	of storage:	- 10° - +50°C (without paper roll)
	Humidity:	
	of operation:	10% - 85% (no condensation)
	of storage:	10% - 90% (no condensation, without paper roll)

Fiscal parameters	Number of daily records:	2100
	Number of invoices:	No limitation
	Number of VAT rates:	7 (including the rate exempted)
	Number of items in the commodity base:	350.000
	Method of creating the commodity base:	Automatically, during sales
	Admissible ranges of values for the alpha numeric and numeric values:	

Name of the good / service	Capital and small letters, digits, polish characters (in selected code page) and others characters: . , % \ / , the length of the name is the same as the number of characters in the line
Unit price	0,01 .. 429496,7249
Quantity	0,0001 .. 429496,7295
Amount of transaction for one item	0,01 .. 429496,7249
Total of the receipt	0,01 .. 1717986,91
Amount of payment	0,01 .. 1717986,91
Daily amounts (summary):	0,01 .. 42949672,95
Minimum life time of the battery:	5 years
Operation time at battery supply:	48 hours, 6000 lines (after charging 24 hours)
Maximum number of items on a receipt or an invoice	255

Printer of receipts

Type of mechanism:	Thermal, paper cutter
Size of the character	1,41 x 3,39 mm (width x height)
Number of characters in the line/row	48
Max. Speed of printing	32 lines/s

Life

Thermal head	100 km paper
Autocutter	1,5 mln cuts
Mechanism	15 mln lines
MCBF	60 mln lines
MTBF	360 thousand hours

7 DESCRIPTION OF EMERGENCY SITUATIONS

Internal errors dealt with by the printer, in most events are signaled immediately with a sound and printed with the verbal description and error's code. The printout is possible only on non-fiscal printout. In the event of open fiscal receipt, the error is not printed and only signaled with a sound.

Software application must read the error and then it may repeat the same order or sent another order which is correct for the procedure being executed.

Service interference is required when one of the following errors occurs:

- error of the control total of the fiscal microcode,
- fiscal memory is disconnected,
- printer of receipts is disconnected,
- error of the clock of real time,

- inconsistency of fiscal data saved in the fiscal RAM memory or fiscal RAM memory has been deleted.

The only error dealt with automatically by the fiscal microcode is exceeding the time limit for completing the sales transaction. If the receipt has been open for longer than 30 minutes, it becomes cancelled automatically.

Errors related to the printing mechanism

Message	Code	Description
Lack of paper (receipts station)	0x8101	Insert a new paper roll
Printer's cover is open	0x8105	Check the cover closing
Paper jam	0x8106	See section 4.5
Overheating of the printing head	0x8107	Turn off the printer and wait a few minutes
Error of the cutter	0x8108	See section 4.5, restart the printer, call the service provider
No answer to the question regarding the status	0x8109	Check cables, restart the printer, call the service provider
Lifted printing head	0x810A	Call the service provider
Fatal error of the printing mechanism	0x810B	Call the service provider
The printer is blocked – required service intervention	0x810C	Call the service provider

Errors related to the display

Message	Code	Description
The client's display is not connected	0x8004	Check the display's cables, call the service provider

Errors related to the fiscal memory

Message	Code	Description
Signature of the fiscal memory has not been generated or is incorrect	0x3201	
Fiscal memory has already been signed	0x3202	
Fiscal memory has already been formatted	0x3203	
Fiscal memory is not empty	0x3204	
Access to the fiscal memory is not allowed	0x6015	
Fiscal memory is read-only	0x601C	
Fiscal memory is not formatted	0x601E	
Fiscal memory is not unblocked	0x601F	
No access to fiscal memory	0x6400	
Error of saving to the fiscal memory	0x6401	
Error of reading from the fiscal memory	0x6402	
Fiscal memory not connected or not formatted	0x6409	Call the service provider
Structure of record in the fiscal memory is not correct	0x640A	
Incorrect country code or model of the printer saved in the fiscal memory	0x640D	
Maximum number of saved heading has been reached	0x640E	
Fatal error of the fiscal memory	0x640F	
Fiscal memory is not consistent with data in ram. Delete the ram memory	0x6410	
Important records in the fiscal memory are damaged	0x6411	
Error at totalizer's display from the fiscal memory	0x6412	
Replaced fiscal memory	0x6415	

Errors related to the data transmission

Message	Code	Description
---------	------	-------------

Error of data transmission to the Central Cash Registers' Repository	0xE010	Check correctness of the connection of the cable to internet, lack of connection with the CRK server
--	--------	--

Errors requiring immediate calling service provider

Message	Code
Lack of record of SHA signature	0x6030
SHA signatures are different	0x6031
Totalizers are damaged	0x60F0
Incorrect data in the protected memory	0x60F5
Damaged data	0x7204
No card	0x7205
No free space on the card	0x7207
Unpaired protected memory	0x7304
Internal error protected memory	0x7307
Damaged RAM	0x8000
Damaged RTC	0x8001
Deleted RAM	0x8002
Not set RTC	0x8003
Low voltage power supply, one may not print or save data to the fiscal memory	0x8007
TPM not ready yet	0x8500
Error of TPM module	0x8501

NOTE!
In the event of any other error or observing unusual cash register's actions – call the service provider.

8 ADDITIONAL SOFTWARE

On the devices' manufacturer's website, there are available: software, instructions and certificates.

<https://www.exorigo-upos.pl/urzadzenia/drukarka-fiskalna-upos-fp-20-online/>



The software for the proper work requires the operation system, minimum Windows 7 (library .Net in the version 4.5).

Software	Description
SimpleTool	Service software enabling to conduct the process of printer's fiscalization, the preview of its condition and setting of usable parameters, such as loading graphics and setting its printout on documents, change of the header.

MemoryViewer Software for local review and print of content of the fiscal and protected memory.

The fiscal printer UPOS-FP20 ONLINE has achieved homologation based on the decision of the Central Office of Measures: PT 41/2019 z dn. 05.11.2019r.



Producer:

Exorigo-Upos S.A.

Skierniewicka 10A
01-230 Warsaw

tel. +48 22 12 20 400
info@exorigo-upos.pl

www.exorigo-upos.pl